

Gate Turn-off Thyristors ~ All types

Symmetrical Types

Type	V_{DRM} $V_{GK} = -2V$ (Note 1) (V)	V_{RRM} (Note 1) (V)	V_{GK} (Note 2) (V)	I_{TGM} @ C_s		$I_{T(AV)}$ $T_{SHK} = 55^\circ C$ (Note 3) (A)	$I_{T(RMS)}$ $T_{CASE} = 25^\circ C$ (Note 3) (A)	$I_{TSM(1)}$ 10ms (Note 4) (kA)	$I_{TSM(2)}$ 2ms (Note 4) (kA)	I^2t (Note 4) (A ² s)
				(A)	(μF)					
WG5012Rxx to 25Rxx	1200-2500	100-2000	18	500	1	330	640	4	7.2	80 x 10 ³
WG6006Rxx to 18Rxx	600-1800	100-1400	18	600	1.5	430	870	5	9	130 x 10 ³
WG9006Rxx to 14Rxx	600-1400	100-1100	18	900	3	445	890	5.5	9.8	150 x 10 ³
WG10026Rxx to 36Rxx	2600-3600	100-2800	18	1000	2	600	1180	10	18	500 x 10 ³
WG10037Rxx to 45Rxx	3700-4500	100-3600	18	1000	2	470	920	7	13	240 x 10 ³
WG12008Rxx to 25Rxx	800-2500	100-2000	18	1200	3	790	1600	13	23	840 x 10 ³
WG12026Rxx to 36Rxx	2600-3600	100-2800	18	1200	3	600	1180	10	18	500 x 10 ³
WG12037Rxx to 45Rxx	3700-4500	100-3600	18	1200	3	470	920	7	13	240 x 10 ³
WG14008Rxx to 25Rxx	800-2500	100-2000	18	1400	4	790	1600	13	23	840 x 10 ³
WG15008Rxx to 25Rxx	800-2500	100-2000	18	1500	3	1020	1995	18	32.5	1.6 x 10 ⁶
WG15026Rxx to 45Rxx	2600-4500	100-3600	18	1500	3	800	1580	16	29	1.3 x 10 ⁶
WG18008Rxx to 25Rxx	800-2500	100-2000	18	1800	4	1100	2150	20	36	2 x 10 ⁶
WG18026Rxx to 45Rxx	2600-4500	100-3600	18	1800	4	850	1685	17	30	1.4 x 10 ⁶

Fast Symmetrical Types

WG5012FRxx to 25FRxx	1200-2500	100-2000	18	500	1	280	540	3	5.4	45 x 10 ³
WG6006FRxx to 18FRxx	600-1800	100-1400	18	600	1.5	360	700	4	7.2	80 x 10 ³
WG9006FRxx to 14FRxx	600-1400	100-1100	18	900	3	370	730	4.5	8.1	100 x 10 ³
WG10026FRxx to 36FRxx	2600-3600	100-2800	18	1000	2	545	980	8.3	15	340 x 10 ³
WG10037FRxx to 45FRxx	3700-4500	100-3600	18	1000	2	420	820	5.7	10	160 x 10 ³
WG12008FRxx to 25FRxx	800-2500	100-2000	18	1200	3	670	1340	10.5	19	550 x 10 ³
WG12026FRxx to 36FRxx	2600-3600	100-2800	18	1200	3	545	980	8.3	15	340 x 10 ³
WG12037FRxx to 45FRxx	3700-4500	100-3600	18	1200	3	420	820	5.7	10	160 x 10 ³
WG14008FRxx to 25FRxx	800-2500	100-2000	18	1400	4	670	1340	10.5	19	550 x 10 ³

Anode Short Types

WG5026S to 45S	2600-4500	18	18	500	1	390	760	4.5	8.1	100 x 10 ³
WG7008S to 25S	800-2500	18	18	700	1	555	1085	7	13	240 x 10 ³
WG8026S to 45S	2600-4500	18	18	800	1	440	855	5.5	9.8	150 x 10 ³
WG8046S to 60S	4600-6000	18	18	800	2	445	880	5.7	10	160 x 10 ³
WG10008S to 25S	800-2500	18	18	1000	2	595	1160	7.5	13	280 x 10 ³
WG10026S to 45S	2600-4500	18	18	1000	2	545	1065	8	14	320 x 10 ³
WG15008SP to 25SP	800-2500	18	18	1500	3	1170	2290	17	30	1.4 x 10 ⁶
WG15026SP to 45SP	2600-4500	18	18	1500	3	885	1730	16	29	1.3 x 10 ⁶
WG20008SP to 25SP	800-2500	18	18	2000	4	1260	2480	20	36	2 x 10 ⁶
WG20026SP to 45SP	2600-4500	18	18	2000	4	950	1860	18	32.5	1.6 x 10 ⁶
WG25008SM to 25SM	800-2500	18	18	2500	4	1915	3755	20	36	2 x 10 ⁶
WG30008S to 25S	800-2500	18	18	3000	6	1650	3240	20	36	2 x 10 ⁶
WG30026S to 45S	2600-4500	18	18	3000	4	1240	2510	20	36	2 x 10 ⁶

T_j = 125°C unless indicated

V_{TM} $I_T = I_{TGM}$ (Note 5) (V)	I_{GT} @ 25°C (A)	V_{GT} @ 25°C (Typ) (V)	t_{gt} @ I_{GM} $I_T = I_{TGM}$ (Note 6) (μ s) (A)		t_{gn} @ di_{go}/dt $I_T = I_{TGM}$ (Note 6) (μ s) (A/ μ s)		t_{on} (min) (Note 7)	t_{off} (min) (Note 8)	Rth j-hs (K/W)	Wt (g)	Mounting Force (kgf)	Fig. No.	Type
			(μ s)	(A)	(μ s)	(A/ μ s)	(μ s)	(μ s)					
2.5	1.0	0.8	5	10	11	20	20	90	0.065	120	450-900	1	WG5012 to 25
2.1	1.0	0.8	5	12	11	20	20	70	0.063	120	450-900	1	WG6006 to 18
2.3	1.0	0.8	5	15	13.5	20	20	75	0.063	120	450-900	1	WG9006 to 18
3.5	1.3	0.9	8	20	21	20	20	130	0.027	480	1500-2500	3	WG10026 to 36
5	1.3	0.9	8	20	21	20	20	155	0.027	480	1500-2500	3	WG10037 to 45
2.7	1.3	0.9	8	20	22	20	20	100	0.027	480	1500-2500	3	WG12008 to 25
3.8	1.3	0.9	8	20	23	20	20	140	0.027	480	1500-2500	3	WG12026 to 36
5.5	1.3	0.9	8	20	23	20	20	170	0.027	480	1500-2500	3	WG12037 to 45
2.9	1.3	0.9	8	20	24	20	20	120	0.027	480	1500-2500	3	WG14008 to 25
3	4	0.9	6	40	21	30	30	130	0.017	850	2000-3000	4	WG15008 to 25
4.5	4	0.9	6	40	21	30	30	210	0.017	850	2000-3000	4	WG15026 to 45
3	4	0.9	6	40	22	30	30	135	0.017	850	2000-3000	4	WG18008 to 25
4.5	4	0.9	6	40	22	30	30	220	0.017	850	2000-3000	4	WG18026 to 45

3.2	1.5	0.8	3	30	6	40	10	60	0.065	120	450-900	1	WG5012 to 25
2.6	1.5	0.8	3	30	6	40	10	45	0.063	120	450-900	1	WG6006 to 18
3	1.5	0.8	3	40	7	40	10	50	0.063	120	450-900	1	WG9006 to 18
4.5	2	0.9	7	40	14	40	20	105	0.027	480	1500-2500	3	WG10026 to 36
6	2	0.9	7	40	14	40	20	125	0.027	480	1500-2500	3	WG10037 to 45
3.3	2	0.9	7	40	13	40	20	80	0.027	480	1500-2500	3	WG12008 to 25
5	2	0.9	7	40	15.5	40	20	120	0.027	480	1500-2500	3	WG12026 to 36
6.7	2	0.9	7	40	15.5	40	20	140	0.027	480	1500-2500	3	WG12037 to 45
3.5	2	0.9	7	40	15	40	20	100	0.027	480	1500-2500	3	WG14008 to 25

3.2	2	1	6	20	14	25	20	80	0.038	250	1000-1700	2	WG5026 to 45
2.3	2	1	4	20	16	25	20	70	0.038	250	1000-1700	2	WG7008 to 25
3.5	2	1	6	20	17	25	20	90	0.038	250	1000-1700	2	WG8026 to 45
5	2	1	6	20	15	25	20	150	0.027	480	1500-2500	3	WG8046 to 60
2.5	2	1	4	20	19	25	20	80	0.038	250	1000-1700	2	WG10008 to 25
4	2	1	6	20	18	25	20	80	0.027	480	1500-2500	3	WG10026 to 45
2.5	2	0.9	5	40	17	30	20	80	0.017	850	2000-3000	4	WG15008 to 25
3.8	2	0.9	5	40	19	30	20	110	0.017	850	2000-3000	4	WG15026 to 45
2.6	2	0.9	5	40	20	30	20	90	0.017	850	2000-3000	4	WG20008 to 25
4	2	0.9	5	40	22	30	20	110	0.017	850	2000-3000	4	WG20026 to 45
2.2	6	0.8	5	50	24	40	30	90	0.012	1400	3000-4000	5	WG25008 to 25
3	6	0.8	4	60	30	40	30	110	0.012	1400	3000-4000	5	WG30008 to 25
4	5	0.8	4	60	30	40	30	125	0.012	1400	3000-4000	5	WG30026 to 45

Tj = 125°C unless indicated

Gate Turn-off Thyristors ~ Notes

Device Selection

Westcode Gate turn-off thyristors are identified by the prefix 'WG' and available in three types, each with its most appropriate application area. Identification of the nominal turn-off current (I_{TGO}) is given by the first two or three digits after the prefix (x10), with the next two digits (x100) identifying the forward blocking voltage (V_{DRM}) the remainder of the code defining the device type and any reverse blocking voltage (V_{RRM}) capability.

Example: a) WG5018 gives $I_{TGO} = 500A$ & $V_{DRM} = 1800V$

b) WG15042 gives $I_{TGO} = 1500A$ & $V_{DRM} = 4200V$

Symmetrical Types

These can be identified either by no suffix, or the suffix 'R' followed by the required V_{RRM} . Devices with maximum V_{DRM} less than 2.5kV and I_{TGO} less than 1200A are suitable for general application, offering a good on-state to switching loss relationship. Higher voltage and current devices of this type are primarily aimed at applications which require a higher V_{RRM} rating than that offered by the Anode Shorted equivalents. Symmetrical types have a minimum V_{RRM} of 100V with a capability of up to 80% of maximum of the V_{DRM} for that type, if specified at time of order.

Identification of required V_{DRM} and V_{RRM}
Example is WG50xxRxx series

- If $V_{RRM} = 100V$ then no suffix.
Example: $V_{DRM} = 2100V$ & $V_{RRM} = 100V$,
Type is WG5021.
- If $V_{DRM} = V_{RRM}$ then just suffix 'R'.
Example: $V_{DRM} = V_{RRM} = 1900V$,
Type is WG5019R.
- If $V_{DRM} \neq V_{RRM} > 100V$ then suffix 'R' plus V_{RRM} grade.
Example: $V_{DRM} = 2300V$ & $V_{RRM} = 1100V$,
Type is WG5023R11.

High Frequency Symmetrical Types

These device types are aimed at applications with switching frequencies up to 5kHz, and offer low switching losses with fast turn-off, at the cost of higher on-state losses, when compared to the standard symmetrical types. High Frequency Symmetrical types have a minimum V_{RRM} of 100V, with a capability of up to 80% of the maximum V_{DRM} for that type, if specified at time of order. Identification of the required blocking voltage is the same as for the standard symmetrical types, except for the addition of an 'F' in the device code.
Example: WG5021F or WG5023FR11.

Anode Shorted types

For general application where a series or anti-parallel diode is used. Anode Shorted devices are particularly appropriate where a high switching current or blocking voltage is required.

Identification is by the suffix 'S', 'SM' or 'SP'.
Example: WG8054S or WG25022SM.

Notes

- V_{DRM} & V_{RRM} available in 100V intervals.
- V_{GK} may be exceeded during the turn-off avalanche period.
- Double-side cooled, single phase; 50Hz, 180° half sinewave.
- $I_{TSM}(8.3msec) = I_{TSM}(10msec) \times 1.066$
 $I^2t(8.3msec) = I^2t(10msec) \times 0.943$
@ initial T_j 125°C.
- Forward gate current (I_G) = $2 \times I_{GT}$ @ 25°C.
- With RCD snubber, R = 5 ohms and C is the value as for I_{TGO}
- Does not include snubber discharge time; refers only to minimum time for whole device to be in conduction with anode current $di/dt > 10A/\mu s$
- Minimum time to re-fire the device. The gate drive circuit may require a longer period of low impedance operation to ensure full extraction of the tail current.
- Coaxial Gate Leads available for outlines 2-5

Associated Diodes

For suitable Snubber and Anti-parallel diodes consult Westcode.

Gate Turn-off Thyristors ~ Outlines

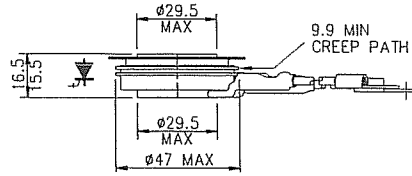
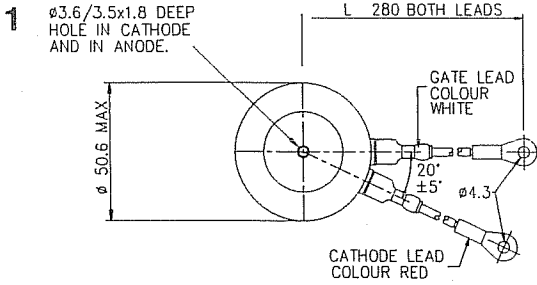

101A296

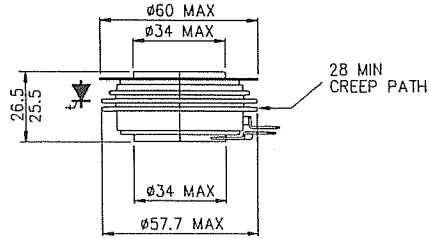
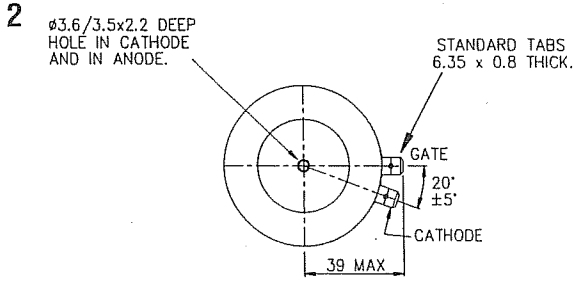

101A324

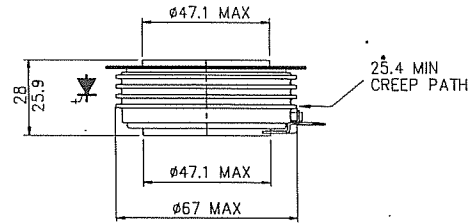
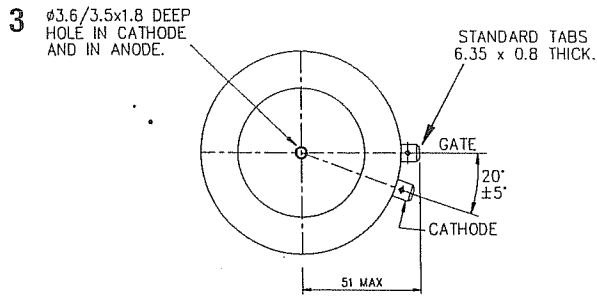

101A288

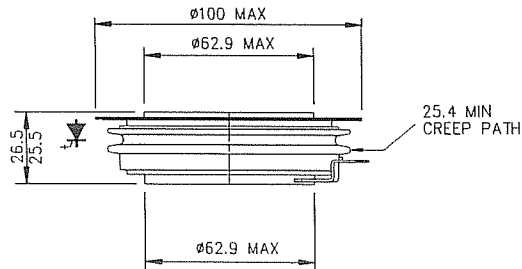
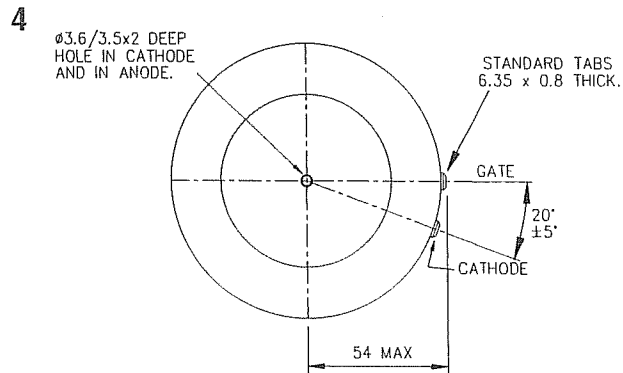

101A295

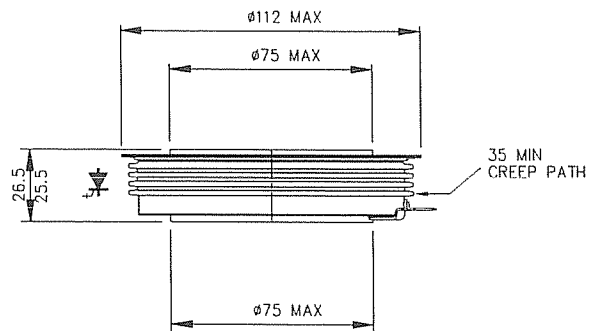
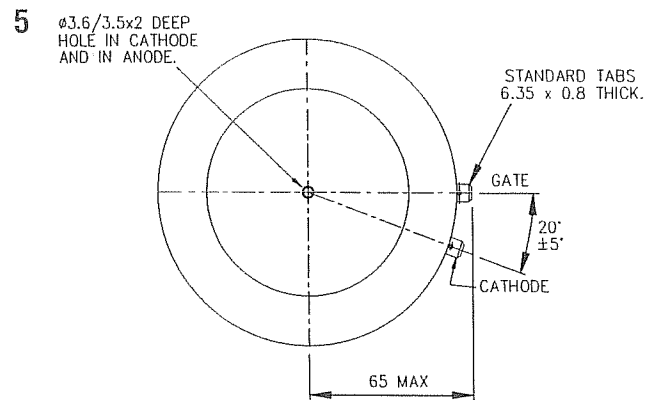

101A316

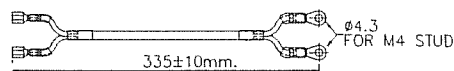

124A143H355

Mounting Procedures

It is important to observe the correct mounting procedures when using Power Semiconductors to ensure effective cooling, good current conduction and reliability. Heatsink preparation is a vital part of the procedure .

(1) ALUMINIUM HEATSINKS^(a) for CAPSULE and FLAT BASE devices:–

Apply a small amount of mounting grease^(b) to the heatsink. Scrub the heatsink area with a wire brush (a 25mm rotary wire cup brush is ideally suited); this action produces a 'slurry'. Clean the mounting surface, or surfaces, in the case of double cooling. Apply a thin film of mounting grease to the semiconductor, and clamp in position observing the clamping procedures below. Warning: a small amount of grease of approximately 0.1mm diameter should be squeezed out of the device/heatsink joint. Excessive use of grease will cause a high voltdrop across the joint and affect heat transfer.

(2) STUD BASE devices:–

Ensure that the device contact surface is clean (a scouring pad, such as 'Scotchbrite', will remove dirt effectively) then apply a thin film of mounting grease to the device ensuring that the threads are clean and free of mounting grease.

Assembly procedures are important:

(1) CAPSULE devices:–

Using 'bar' clamps, either double side or single side, it is important to ensure that all faces are parallel before tightening. The screws should be 'finger' tightened initially, then, using a suitable spanner (wrench) the nuts should be alternately tightened half a turn until the pressure indicating system shows that the required pressure has been achieved.

Using a 'box' clamp, position it over the device ensuring that the pins are correctly located. Position the square steel plate over the central rod, feed bolts (with shakeproof washer) through the clamp whilst holding it firmly in place. Screw the bolts 'finger tight', then alternately, clockwise, half a turn until the box touches the heatsink all the way round.

(2) FLAT (SQUARE) BASE devices:–

Apply mounting grease as for capsules. Ensure that no mounting grease or lubrication is on the fixing screws, then 'finger' tighten them, followed by a torque controlled spanner (wrench) to 1.66 - 2.07 Kgm torque.

(3) STUD BASE devices:–

Ensure that no mounting grease is on the screw thread. Tighten only the hexagonal base using a torque controlled spanner (wrench) to the limit stated for the device.

WESTCODE offer a range of mounting clamps for capsule devices:

<u>Pole Face dia.</u>	<u>Basic Clamp</u>	<u>Type of Clamp</u>
19mm	CMK 450B19M	Box Clamp
25mm	CMK 450x56M	Bar/single/double
25mm	CMK 450B25M	Box Clamp
29.5mm (GTO only)	CMK 550x56M	Bar/single/double
34mm	CMK 1130x76M	Bar/single/double
34mm	CMK 1500B34M	Box Clamp
47mm (GTO only)	CMK 2100x76M	Bar/single/double
47mm	CMK 2140x76M	Bar/single/double
63mm (GTO only)	CMK 2500x116M	Bar/single/double
63mm	CMK 3000x116M	Bar/single/double
75mm (GTO only)	CMK 3500x116M	Bar/single/double
73mm	CMK 4000x116M	Bar/single/double
87mm (GTO only)	CMK 5000x128M	Bar/single/double
87mm	CMK 7000x128M	Bar/single/double

NOTES :

- (a) Recommended machining tolerances over the device mounting area – Flatness 0.03mm, Roughness 1.6µ metres Ra
- (b) Recommended mounting grease – ILEX SCX 13 or PENETROX A-13